

Caston III

Crane Scale

- Available in 10000 lb × 2, 20000 lb × 5, 30000 lb × 10, 40000 lb × 10, 60000 lb × 20, 100000 lb × 20 Capacities
- Easy to Read 1.5" LED Display
- Wireless Remote Control Standard
- Environmentally Sealed to IP 65 Standards.
- Battery Operated



ISO 9001 certified

CAS
S • C • A • L • E

CASTON III Crane Scale

FEATURES

- Battery Operated w/ Low Battery Indication
- Rechargeable Battery Pack
- Spare Battery Pack and Charger Included as Standard
- Easy to Read 1.5" LED Display
- Remote Control Included as Standard
- On, Off, Zero, Tare and Hold (Manual or Automatic) Functions
- Auto Span Adjustment
- Auto Zero Tracking

SPECIFICATIONS

Model	5THD	10THD	15THD	20THD	30THD	50THD
Weighing Capacity	10000 × 2 lbs 5000 × 1 kg	20000 × 5 lbs 10000 × 2 kg	30000 × 10 lbs 15000 × 5 kg	40000 × 10 lbs 20000 × 5 kg	60000 × 20 lbs 30000 × 10 kg	100000 × 20 lbs 50000 × 10 kg
Maximum Tare	Full Tare					
Display Type	LED (1.5 inch)					
Operating Power	DC 6V					
Power Source	AC 120V, 50/60Hz					
Display Designators	Zero, Tare, Hold, Batt.					
Power Consumption	1.2W					
Operating Temperature	-10°C ~ +40°C (14°F ~ 104°F)					

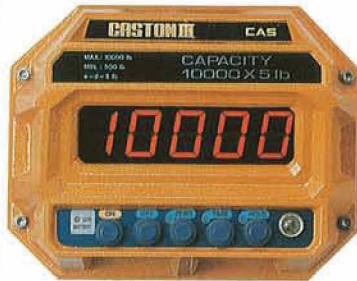

▲ Display & Keyboard

◀ Battery pack Installation



ALGEN SCALE CORP.

390-13 Knickerbocker Ave ❖ Bohemia, NY 11716
 631-342-1975 ❖ FAX 631-342-1979
 www.algen.com ❖ info@algen.com

DIMENSIONS

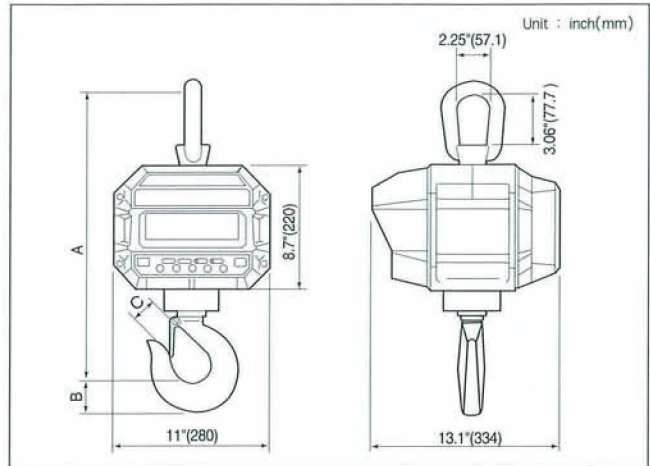

Model	A	B	C	Product Weight
5THD	20.1" (512)	1.75" (44.5)	1.69" (42.9)	68.3 lb / 31 kg

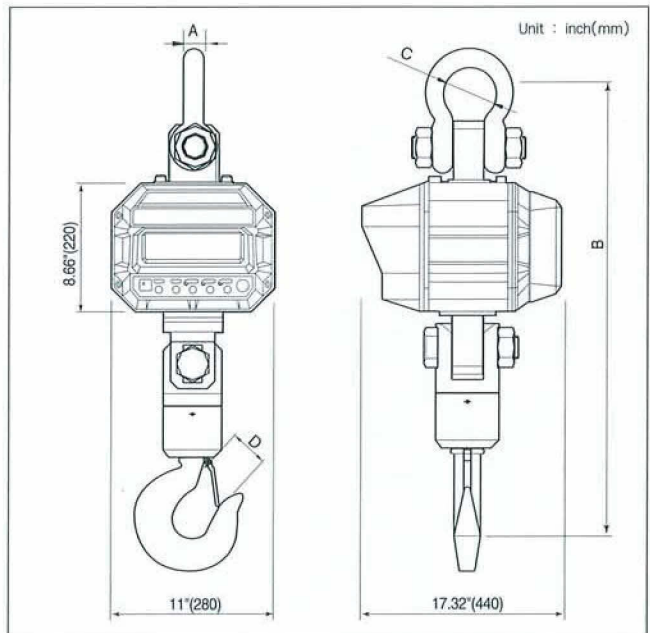

Model	A	B	C	D	Product Weight
10 THD	1.26" (32)	33.27" (845)	3.27" (83)	2.25" (57.2)	97 lb / 44 kg
15 THD	1.50" (38)	34.88" (886)	3.90" (99)	2.50" (63.5)	116.7 lb / 53 kg
20 THD	1.77" (45)	38.98" (990)	4.96" (126)	3.39" (86)	167.5 lb / 76 kg
30 THD	1.97" (50)	47.24" (1,200)	5.43" (138)	4.25" (108)	484.6 lb / 220 kg
50 THD	2.56" (65)	59.84" (1,520)	7.08" (180)	5.75" (146)	859.8 lb / 390 kg